

2019

Fury

Owner's Manual Supplement



WARNING

READ THIS SUPPLEMENT AND YOUR GT BICYCLE OWNER'S MANUAL. Both contain important safety information. Keep both for future reference.

Safety Messages

In this supplement, particularly important information is presented in the following ways:



WARNING

Indicates a hazardous situation which, if not avoided, may result in death or serious injury.

NOTICE

Indicates special precautions that must be taken to avoid damage.

The following symbols are used in this manual:

Symbol	Name	Description
	NGLI-2 synthetic grease	Apply NGLI-2 synthetic grease.
	Carbon gel	Apply carbon gel (friction paste) KF115/
	Medium-strength removable thread lock	Apply Loctite® 242 (blue) or equivalent.

GT Supplements

This manual is a “supplement” to your [GT Bicycle Owner’s Manual](#).

This supplement provides additional and important model specific safety, maintenance, and technical information. It may be one of several important manuals/supplements for your bike; obtain and read all of them.

Please contact your Authorized GT Dealer immediately if you need a manual or supplement, or have a question about your bike. You may also contact us using the appropriate country/region/location information.

You can download Adobe Acrobat PDF versions of any manual/ supplement from our website: <http://www.gtbikes.com>.

Contacting GT

GT USA

Cycling Sports Group, Inc.
1 Cannondale Way, Wilton CT,
06897, USA
1-800-726-BIKE (2453)

Cycling Sports Group Europe B.V

Mail: Postbus 5100
Visits: Hanzepoort 27
7570 GC, OLDENZAAL, Netherlands
Tel: +41 61 551 14 80
Fax:+31 54 151 42 40

International Distributors

Consult the following website to identify the appropriate GT Dealer for your region.

https://www.gtbicycles.com/usa_en/international-distributors/

CONTENTS

- Safety Information2-8
- Technical Information..... 9-24
- Maintenance25
- Replacement Parts 26-27
- Notes28

Your GT Dealer

To make sure your bike is serviced and maintained correctly, and that you protect applicable warranties, please coordinate all service and maintenance through your Authorized GT Dealer.

NOTICE

Unauthorized service, maintenance, or repair parts can result in serious damage and void your warranty.

SAFETY INFORMATION

Important Composites Message

WARNING

Your bike (frame and components) is made from composite materials also known as “carbon fiber.”

All riders must understand a fundamental reality of composites. Composite materials constructed of carbon fibers are strong and light, but when crashed or overloaded, carbon fibers do not bend, they break.

For your safety, as you own and use the bike, you must follow proper service, maintenance, and inspection of all the composites (frame, stem, fork, handlebar, seat post, etc.) Ask your GT Dealer for help.

We urge you to read PART II, Section D. “Inspect For Safety” in your [GT Bicycle Owner's Manual](#) BEFORE you ride.

You can be severely injured, paralyzed or killed in an accident if you ignore this warning.

Inspection & Crash Damage Of Carbon Frames/Forks

WARNING

After A Crash Or Impact:

Inspect frame carefully for damage (See PART II, Section D. Inspect For Safety in your [GT Bicycle Owner's Manual](#).)

Do not ride your bike if you see any sign of damage, such as broken, splintered, or delaminated carbon fiber.

Any of the following may indicate a delamination or damage:

- An unusual or strange feel to the frame
- Carbon which has a soft feel or altered shape
- Creaking or other unexplained noises,
- Visible cracks, a white or milky color present in carbon fiber section

Continuing to ride a damaged frame increases the chances of frame failure, with the possibility of injury or death of the rider.

Intended Use



The intended use of all models is ASTM CONDITION 5, Downhill

WARNING

Understand your bike and its intended use. Using your bike the wrong way is dangerous.

Please read your [GT Bicycle Owner's Manual](#) for more information about Intended Use and Conditions 1-5.

Servicing

WARNING

This supplement may include procedures beyond the scope of general mechanical aptitude.

Special tools, skills, and knowledge may be required. Improper mechanical work increases the risk of an accident. Any bicycle accident has risk of serious injury, paralysis or death.

To minimize risk we strongly recommend that owners always have mechanical work done by an Authorized GT Dealer.

Gravity, Freeriding & Downhill Riding

WARNING

GRAVITY, FREERIDING AND OTHER FORMS OF “EXTREME RIDING” ARE EXTREMELY DANGEROUS. YOU CAN BE SEVERELY INJURED OR KILLED IN A SERIOUS ACCIDENT.

Gravity, Freeriding, jumping, hucking, dirt jumping, mountaincross, downhill, slalom, slopestyle, urban or street riding or other evolving forms of extreme or hard core mountain biking are inherently dangerous and can lead to serious accidents. Wear all safety gear and be sure your bike is in excellent condition. Follow all the instructions and warnings below. These steps will reduce, but not eliminate, the inherent risks. Even with state of the art protective safety gear you could be seriously injured, paralyzed or killed. If you do not want to take these risks, do not engage in this type of riding.

Fundamental Risk

Freeriding, jumping, hucking, dirt jumping, mountaincross, downhill, slalom, slopestyle, urban or street riding. It seems that everywhere you look, from Mountain Dew® commercials to the X-Games® to the Red Bull® Rampage, riders are grabbing big air and sticking sick drops. And it sure looks fun.

But what the videos and bike magazines and ads don't always tell you is that extreme riding takes an amazing amount of skill. Some of the riders you see are well-paid pros who have gradually built up their skills through endless hours of practice, and who have also had their share of stitches, concussions and busted bones (and bikes). Others are daredevils who have chosen to accept or ignore the risks. Would you allow anyone to say that you are so weak in the head, and have such poor judgment that you copy those you see in the media without thought of the serious risks?

The stakes are high if you screw up. Realize too late that you aren't up to the challenge, and you run the risk of major injury or even – say it aloud – death, paralysis. In short, extreme riding carries a high degree of fundamental risk, and you bear the ultimate responsibility for how you ride and what you attempt to pull off. Do you want to avoid these significant risks? Then do not ride this way.

Product Limitations

Problems of pilot error aside, hard-core riding also beats the heck out of your equipment. Although we build and test our bikes to make them tough, there's no way that we can guarantee they'll survive your umpteenth six-foot drop. For starters, there is no industry “jumping” standard. The many circumstances of takeoff, landing, speed, rider technique, etc. are unique. The judgment, lack of judgment or insanity of a rider who may ride a GT bicycle cannot be completely predicted, so it's flat-out impossible to predict how anyone's equipment is going to hold up.

continued on next page.....

continued from previous page...)

Let's get another thing straight. Buying a Freeride bike does not make you any better. Do not confuse the built-in capabilities of equipment with your own capabilities, which must be learned.

Keeping your bike and all its components in good working order is critical, and it's up to you to maintain and inspect it. Even so, your sweet rig isn't going to last forever. Nothing does, particularly bikes and parts that are built to minimize weight and then are subjected to abuse. GT frames carry a warranty, but that's to cover issues with workmanship and/or materials. (See the GT Limited Warranty in this manual). The warranty doesn't mean that they're going to last forever. They're not. The warranty certainly doesn't mean that the bicycle can in any way protect you from injury.

Use of Specialized Protective Gear

GT has long urged the use of helmets. As riskier, extreme downhill and freeriding became part of the sport we communicated frankly about the risks in this freeride warning. We have recently become aware of neck braces, designed for mountain biking and motocross riding, fitted between the rider and helmet, that can decrease the risk of paralysis, spinal cord and neck injuries. As the manufacturer clearly states, these braces cannot prevent all injuries. We urge riders, particularly riders into challenging and risky riding, to investigate and consider prophylactic neck braces (For example, see <http://www.leatt-brace.com/>). A prophylactic neck brace might save your life or keep you out of a wheelchair.

In Conclusion

If you're going hard-core, be smart about it. Always wear a full face helmet, state-of-the-art neck brace, body armor, full-finger gloves, and protective clothing. Choose a bike that's right for you, your riding and terrain, and check it often for signs of fatigue or other trouble. (Your dealer can help you on both fronts.) Read PART II, SECTION B. MOUNTAIN BIKE RIDING. And most importantly, know your limitations. Practice. Stay in control, and carefully, gradually expand your limits – but ride within them.

You can be severely injured, paralyzed, or killed if you ignore this warning.

Maximum Fork Length

Maximum Fork Length is an important frame safety testing specification for front suspension mountain bikes. You must observe the measurement when installing headset parts, headset adapters, installing and adjusting a fork, and selecting replacement forks.

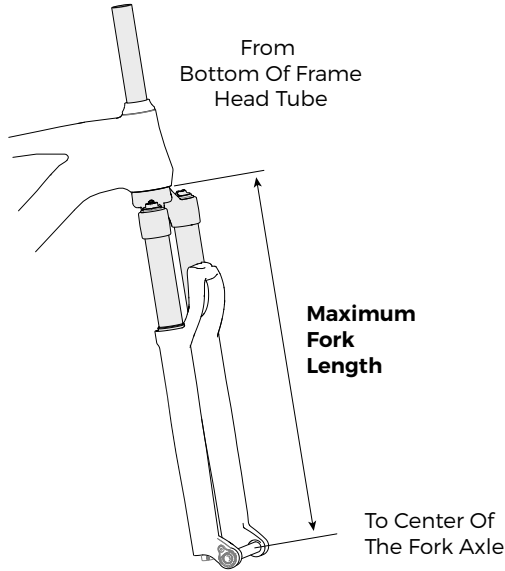

WARNING

You must select a replacement fork not only based on head tube diameter but the critical factor of frame maximum fork length

Do not exceed maximum fork length. Exceeding the MAXIMUM FORK LENGTH limit can overload the frame causing it to break while riding.

Your retailer MUST follow and observe this specification for your bike. For Maximum Fork Length specifications for GT bicycles, see www.gtbikes.com.

You can be severely injured, paralyzed or killed in an accident if you ignore this warning.

Tire Size x Maximum Width

WARNING

Observe the Tire Size x Maximum Width for your bike found in the “Specifications” page of this manual.

Mounting the wrong size tires can result in the tires hitting the fork or frame when riding. If this happens, you can lose control of your bike and you can be thrown off, a moving tire can be stopped because it touches the fork or frame.

Do not mount oversized tires, ones that rub or hit the fork or frame, ones that result in too little clearance, or ones that can hit the fork or frame when the suspension is fully compressed or when riding.

Take care that the tires you select are compatible with your bike's fork or frame design. Also, be sure to follow the manufacturer's recommendations of your front fork and rear shocks.

When you are considering tires for your bike consider...

The actual measured size of a tire may be different than its sidewall marking. Each time you mount a new tire, take the time to inspect the actual clearance between the rotating tire and all parts of the frame. The U.S. Consumer Product Safety Commission (CPSC) requires at least 1/16" (1.6 mm) tire clearance from any part of the bike. Allowing for lateral rim flex and a wheel or rim that is out-of-true will likely mean choosing a rear tire that provides even more clearance than the CPSC recommends.

Ask your dealer for the right tires for your bike and its particular components!

You can be severely injured, paralyzed or killed in an accident if you ignore this warning.

Rear Shocks

WARNING

Select only compatible shocks and forks for your bike. Do not modify your bike in any way to mount one.

Have your shock or fork installed by a professional bike mechanic

Riding with the wrong rear shock can damage the frame. You could have a serious accident. Make sure the total travel, eye-to-eye length, and stroke length of the rear shock you select meet the "Specifications" listed in this manual.

When selecting different shocks or forks for your bike, make sure that the shock or fork you select is compatible with your bike's design and how you will use your bike.

You can be severely injured, paralyzed or killed in an accident if you ignore this warning.

Minimum Seat Post Insert

WARNING

Make sure at least 100 mm of the seat post is inserted into the frame at all times.

Failure to insert the seat post at least 100 mm can place a very high stress on the seat tube top tube junction causing the frame to fail while riding.

Remove the seat post. Measure 100 mm from the bottom of the seat post. Use a permanent marker to mark the post at 100 mm.

When adjusting the seat post height in the seat tube, never adjust the seat post so that the line you mark is above the top edge of the seat tube.

You must also be aware that bicycle seat posts are permanently marked by the manufacturer with a "minimum insert" line on the seat post itself. You must not rely on this marking as an indication of the proper minimum seat post insertion depth.

You can be severely injured, paralyzed or killed in an accident if you ignore this warning.

TECHNICAL INFORMATION

Specifications

Item	Specification	
Wheel Size	Fury 27.5 in	Fury 29 in
Rear Travel	200 mm	190 mm
Head Tube	1.5 in with Fury Specific Cups	
Headset	UPR: 1-1/8 in (41.1 mm OD), LWR: 1-1/8 in (41.1 mm OD)	
Bottom Bracket: Type/ Width	BSA / 83 mm	
Front Derailleur	N/A	
Seat Post: Dia./Binder	31.6 mm / 34.9 mm	
▲ Min. Seat Post Insert	100 mm	
▲ Tire Size x Max. Width (measured)	27.5 in x 2.6 in	29 in x 2.5 in
▲ Max. Fork Length	595 mm	600 mm
Rear Shock: Eye-To-Eye / Stroke / Bushing Width	225 mm / 75 mm / 37.6 mm x 8 mm	
Sag (measured at the shock)	17.1 mm recommended / 20.6 mm maximum	17.5 mm recommended / 20.8 mm maximum
Chain Guide	Chainstay Integrated Idler with ISCG 05	
Rear Brake: Mount Type / Min/Max Rotor Dia.	Post Mount / 203 mm Shimano, 200 mm SRAM	
Rear Axle: Type/Length	Fury Specific TA / 148 x 12 mm	
▲ Intended Use	ASTM CONDITION 5, Downhill	
▲ Max. Weight Limit Total (rider+all equipment):	305 lbs / 138 kg	

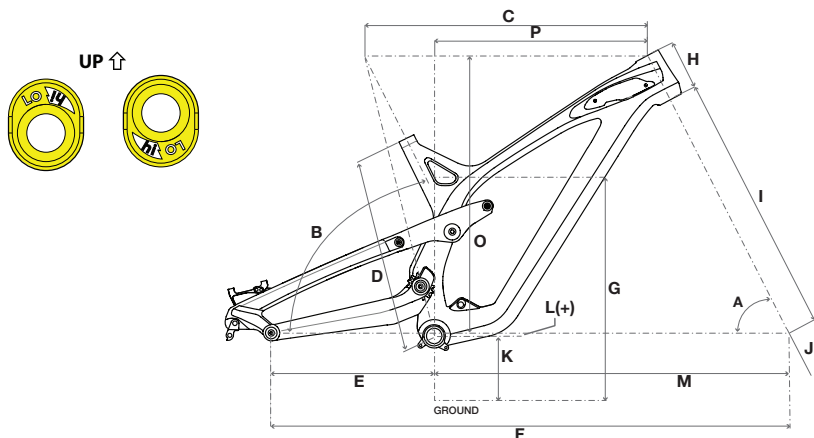

Dimensions = millimeter

Geometry - Fury 27.5

Frame Size		S	M	L			
Flip Chip Orientation		hi	Lo	hi	Lo	hi	Lo
D	Seat Tube Length	420	420	420	420	440	440
C	Top Tube Horizontal	557	557	593	593	620	620
A	Head Tube Angle	62.5°	62°	62.5°	62°	62.5°	62°
B	Seat Tube Angle	74.9°	74.5°	74.9°	74.5°	74.9°	74.5°
G	Standover	700	700	720	720	740	740
H	Head Tube Length	105.0	105.0	105.0	105.0	105.0	105.0
F	Wheelbase	1221	1221	1259	1259	1284	1284
M	Front Center	786	786	824	824	849	849
E	Chainstay Length	437	440	437	440	437	440
L	Bottom Bracket Drop	21.99	28	21.99	28	21.99	28
K	Bottom Bracket Height	354	448	354	448	354	448
J	Fork Rake	32	32	32	32	32	32
L	Stack	612.2	615.7	612	612.7	611.9	615.7
M	Reach	412.2	407	450	445	475	470

All Specifications subject to change without notice.

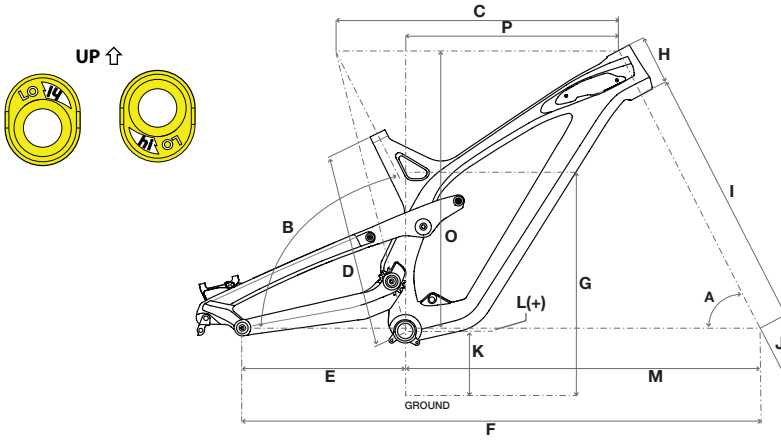

Dimensions = millimeter

Geometry - Fury 29

Frame Size		S	M	L
Flip Chip Orientation		hi Lo	hi Lo	hi Lo
D Seat Tube Length		420	420	440
C Top Tube Horizontal		557	595	620
A Head Tube Angle		62.5°	62°	62.5°
B Seat Tube Angle		74.9°	74.5°	74.9°
G Standover		700	720	740
H Head Tube Length		105.0	105.0	105.0
F Wheelbase		1218.92	1256.92	1285.36
M Front Center		788	826	851
E Chainstay Length		431	431	431
L Bottom Bracket Drop		3.32	3.21	3.14
K Bottom Bracket Height		335	355	335
J Fork Rake		52	52	52
L Stack		612	612	612
M Reach		412	450	475

All Specifications subject to change without notice.

Tightening Torque Order / Frame Assembly

You should observe the following order when connecting frame components:

1. Connect Shock Link to Frame.
2. Connect the Chain Stay to the Frame with Main Pivot and the Idler.
3. Connect the Seat Stay to the Shock Link
4. Connect the Seat Stay to the Chain Stay
5. Complete by tightening fasteners to final torques in this order (1,2,3,4,5) :

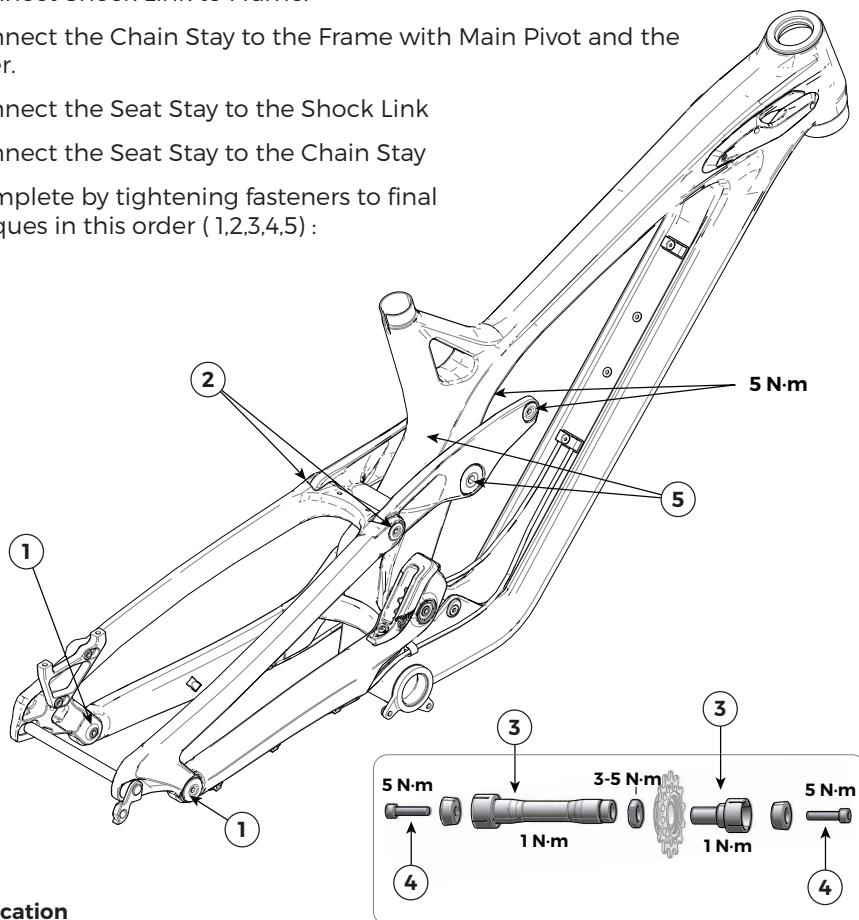

Identification

1. Horst Link Bolts - 6 N·m
2. Seat Stay to Link Pivot Bolts - 6 N·m
3. Main Pivot Axle (2X) - 1 N·m
4. Main Pivot Wedge Bolts - 5 N·m
5. Link to Frame Pivot Bolts - 8 N·m

NOTE: Insert hex keys completely into fasteners prevent damage while turning.

Link /Bearings

Identification

1. Link
2. Top Hat Spacer (2X)
3. Bearing, front (2X)
4. Bearing , center (2X)
5. Bearing, rear (2X)

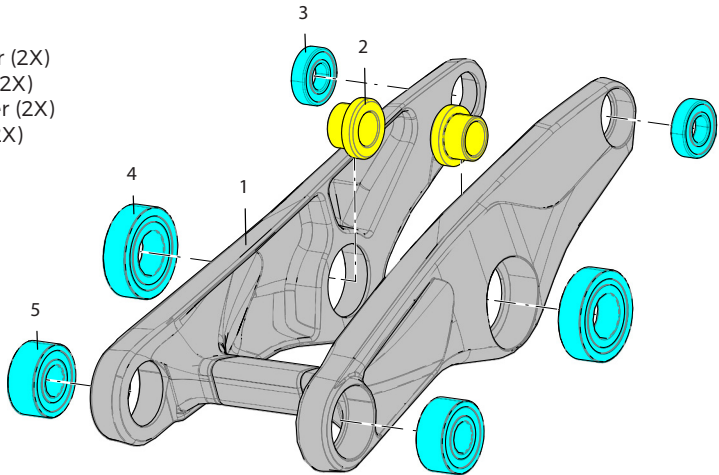

Inspection

- The condition of the bearings, should be inspected periodically. These are normal wear parts so plan to have them replaced as they wear-out.
- To inspect the bearings, disconnect the link to expose the bearings. Rotate the inner race of each bearing with your finger. The rotation should feel smooth without binding. Each bearing should be fixed securely in the opening. Check to make sure each circlip is seated in the grooves. The front bearings should be seated against the inner lip.
- Inspection frequency should be based upon how and where you ride. Evidence of damage would be excessive play, visible wear, or corrosion of bearings.
- If you find any damage to the parts, discontinue riding until all the parts (bearings, pivot axles, spacers) can be replaced. This will help prevent damage elsewhere.
- Do not re-use removed bearings; if removed replace all bearings with new ones.

Link / Frame

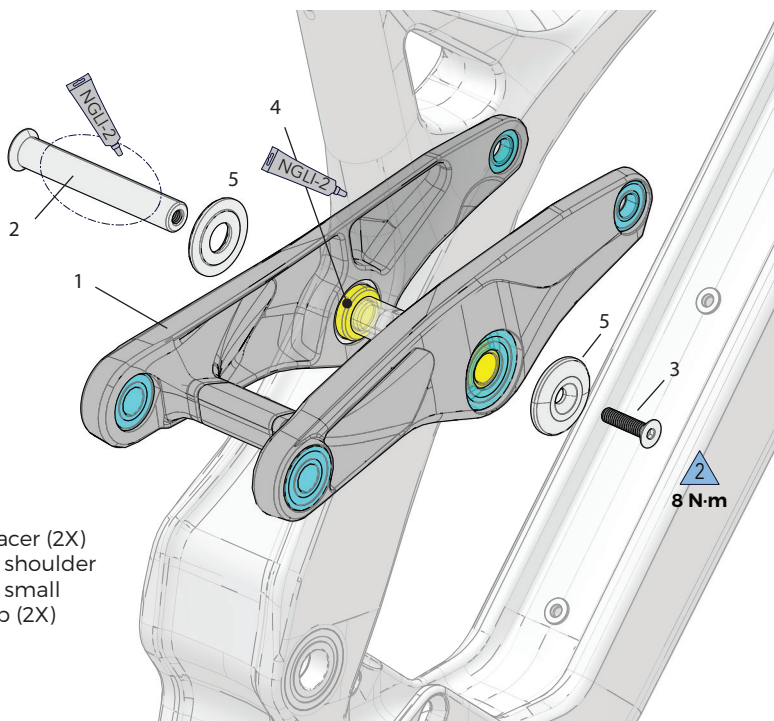

Identification

1. Link
2. Top Hat Spacer (2X)
3. Shock Bolt, shoulder
4. Shock Bolt, small
5. Bearing Cap (2X)

How to install

1. Apply grease and install top hat spacers (2) into link center bearings.
2. Align the link center bearings with frame hole.
3. Slide bearing cap, smooth side out onto the shock bolt.
4. Apply light grease to outside of shock bolt (3) and insert through from non-drive side.
5. Tighten shock bolts to specified torque.

Link / Seat Stay

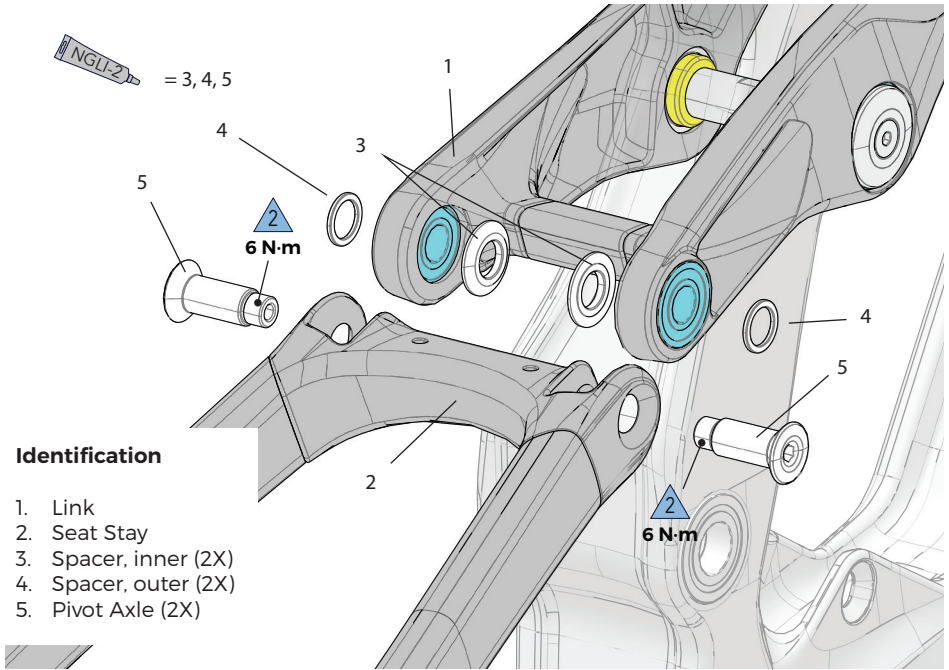

How to install

1. Apply light grease to the bearing faces. This will help hold spacers in place temporarily until the bolt is installed.
2. Install the inner spacers (3) flat side facing bearings.
3. Install the outer spacers (4) onto the outer face of the bearings.
4. Align the seat stay (2) and install the pivot axles (5).
5. Tighten the pivot axles to the specified torque.

Seat Stay / Chain Stay

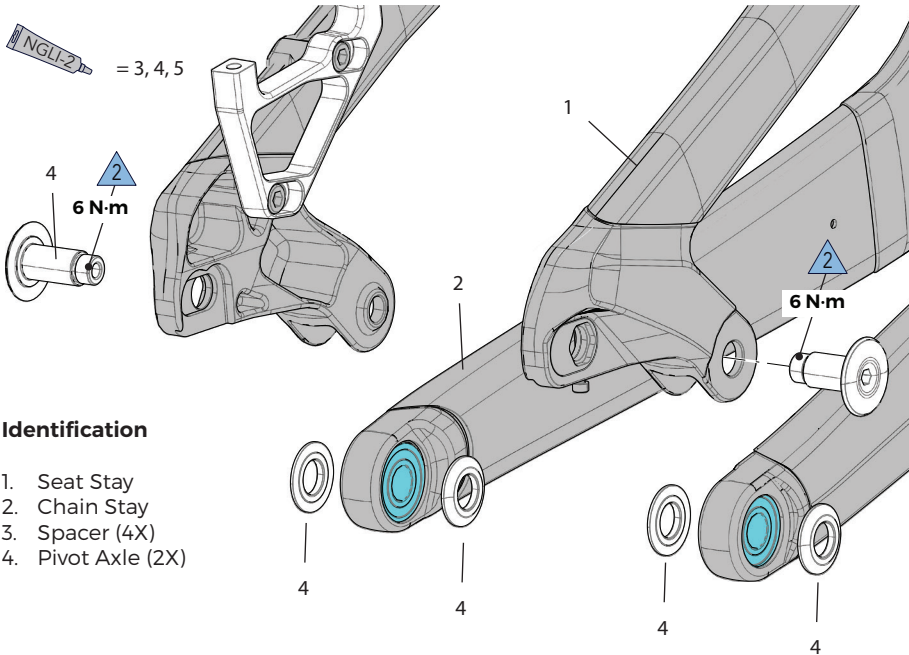

Identification

1. Seat Stay
2. Chain Stay
3. Spacer (4X)
4. Pivot Axle (2X)

How to install

1. Apply light grease to the bearing faces. This will help hold spacers in place temporarily until the bolt is installed.
2. Install the inner spacers (3) flat side facing bearings.
3. Align the chain stay (1) with seat stay (2) and install the pivot axles (4).
4. Tighten the pivot axles to the specified torque.

Main Chain Stay Pivot

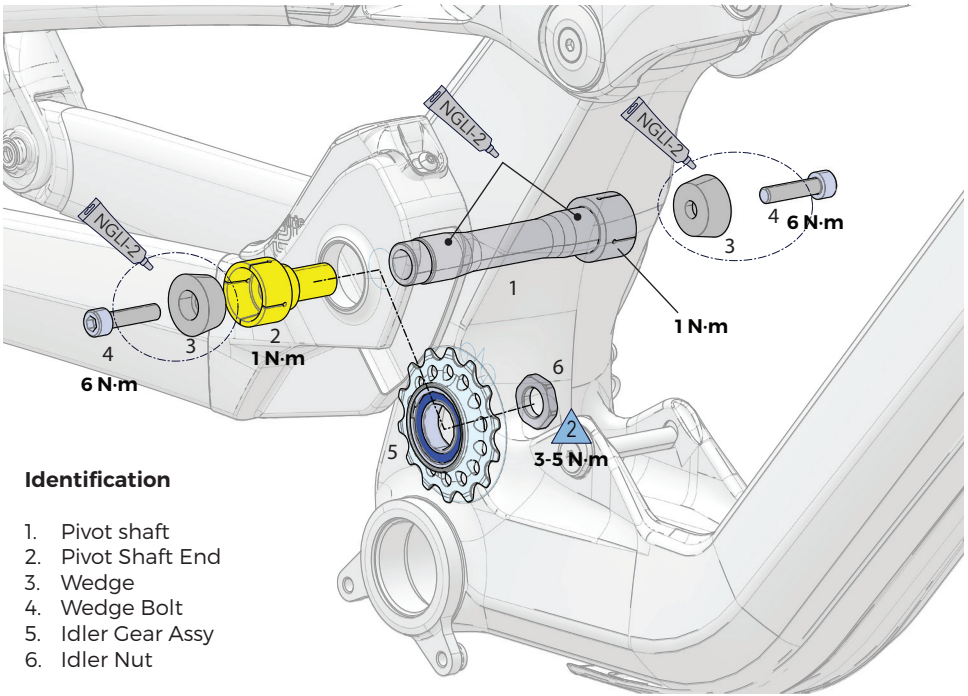

Identification

1. Pivot shaft
2. Pivot Shaft End
3. Wedge
4. Wedge Bolt
5. Idler Gear Assy
6. Idler Nut

How to install

1. Clean and apply grease; install the pivot shaft (1) into frame non-drive side and tighten to specified torque.
2. Insert the pivot shaft end (2) into chain stay and assemble with idler assembly and tighten the nut (6). Assemble pivot shaft end with idler into pivot shaft tighten to specified torque.
3. Clean and apply grease to wedges and bolt threads and insert wedges into pivot ends. Tighten to specified torque.

Idler Sprocket

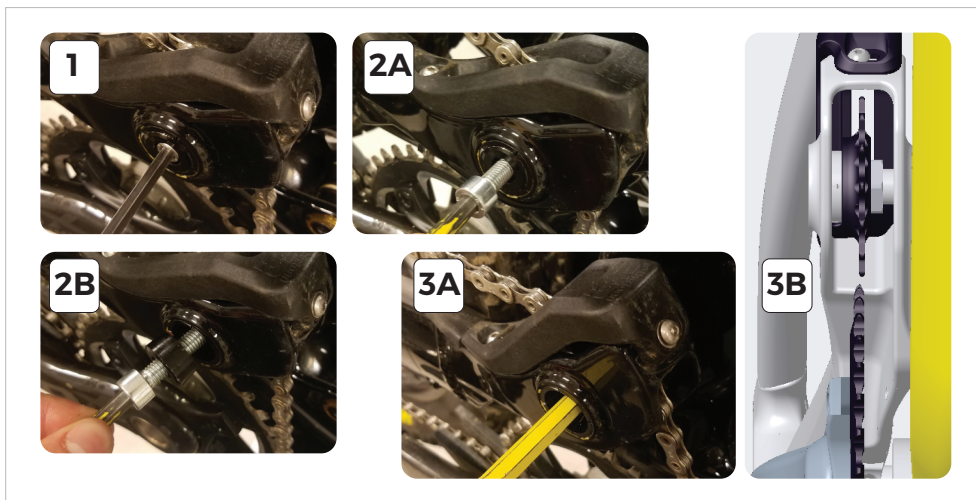

Set-Up Method:

1. Remove the M6 bolt from the expanding wedge.
2. Insert a M8x1 bolt (at least 25mm in length) in the threads of the expanding wedge, and turn clock-wise to extract wedge.
3. Use a M8 hex key to move the idler location, side-to-side. Align the idler so that it is located 1-2 mm inward of the chainring.

NOTE: You may have to flip the idler sprocket to achieve proper chain alignment with the chainring.

Typically SRAM drivetrains have the idler in the position seen in A, while Shimano typically have the orientation seen in B:

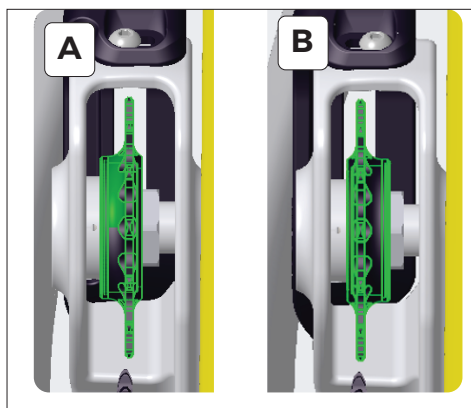

- Using an 18mm cone wrench, hold the nut behind the idler in place, while reinstalling the expanding wedge with the M6 bolt. Make sure to apply grease to the expanding wedge.

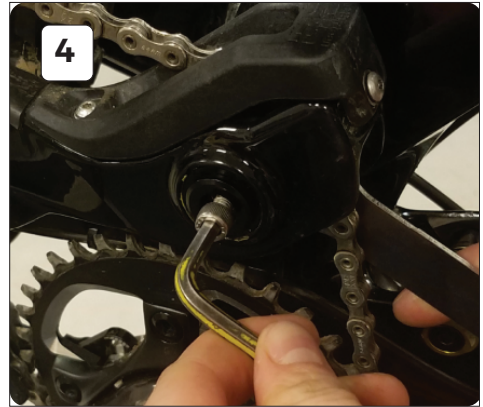

Chain Guide

Set-Up Method:

- Shift to smallest cog on the cassette.
- Align the chain so that the drive-side, inner surface of the chain guide is between 0-1 mm away from the chain.
- Tighten chain guide fastening bolts to 3 Nm.
- Shift through the gears to ensure no or little rubbing occurs on the chain guide while in the smallest cog of the cassette.

NOTES:

- It is OK for the chain to rub when in the larger cogs of the cassette.
- The drivetrain will operate the best with a 7 speed cassette. 10 speed cassettes will function, but with some rubbing on the chain guide in gears 8, 9 and 10 -this is OK.

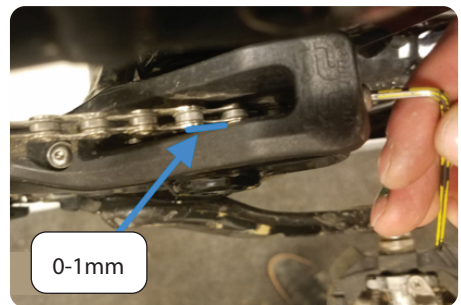

Shock Flip Chip

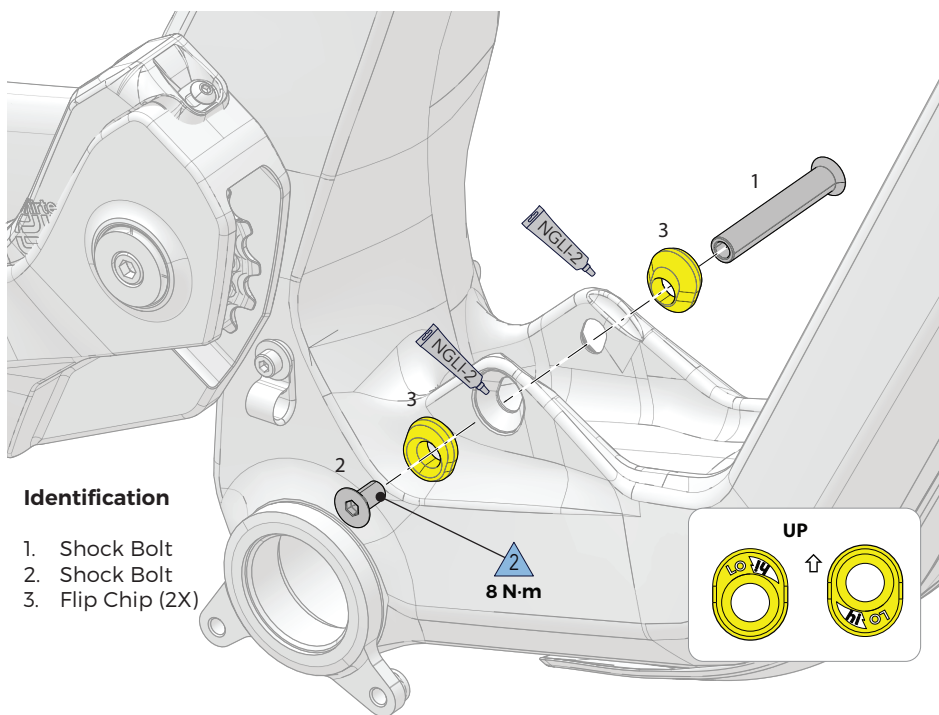

Changing the Rear Shock Flip Chips

1. Place the bike in a workstand.
2. Support the rear wheel to prevent swingarm from dropping when shock is disconnected.
3. Remove the lower shock mounting bolts.
4. Change the Flip Chip orientation in the frame sockets. Be sure to clean the flip chips and frame socket before re-installing. See inset.
5. Install and tighten the shock bolts to the specified torque.

Chain Stay Flip Chip

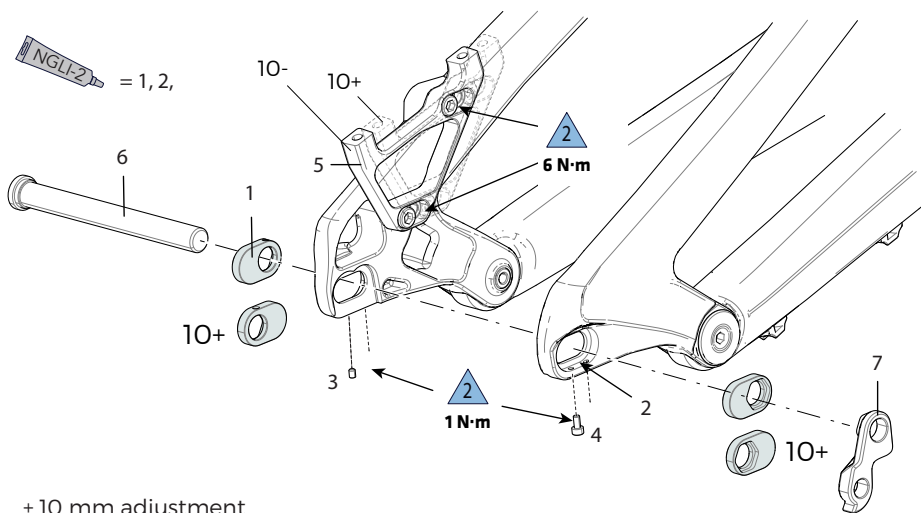

RESULT

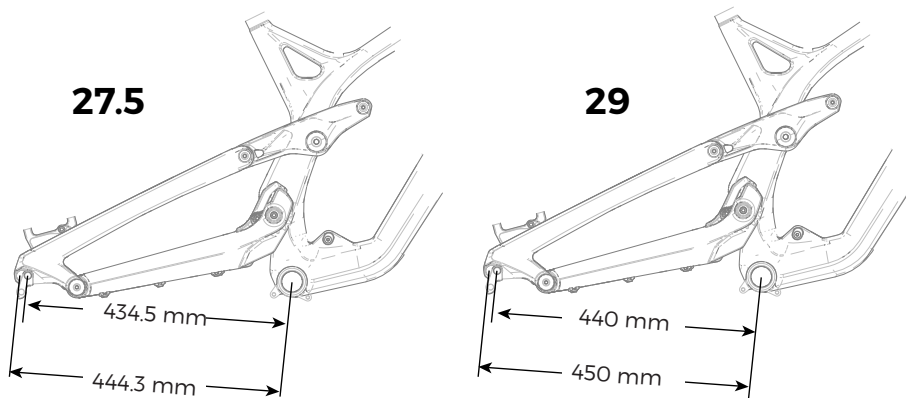

The chain stay flip chip changes the effective length of the chain stay by shifting the position of the rear axle. Before changing flip chips, clean chips and the frame socket and apply light grease. Secure with set screws; do not over-tighten.

Be sure to change the position of the rear brake mount to correspond to the flip chip position.

Cable Routing Requirements

Set-Up:

The length of cable section shown below (in Blue, between the shown downtube cable mount (2) and chain stay zip tie guide (3) must be between 460 mm and 480 mm on all frame sizes. This ensures the cables aren't too short at bottom out, and that they are not too long -so they don't bow out into the cranks. The cable must pass through the BB cable guide (1)

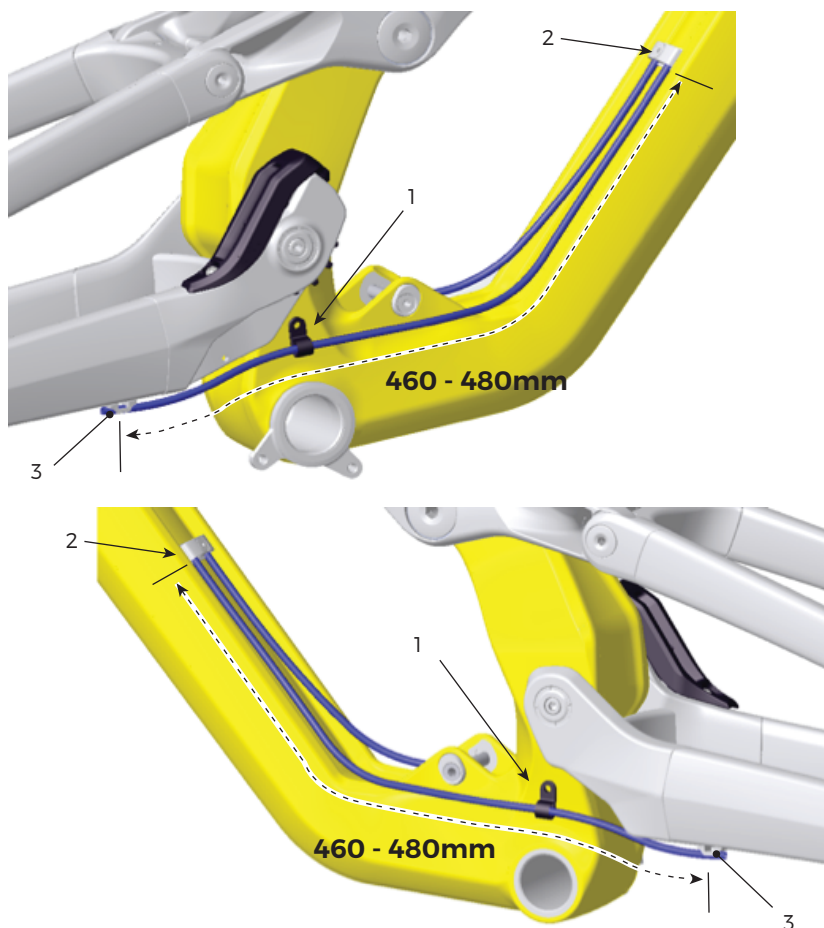



**Cable Slack at
Bottom Out**
(both sides)

⚠ WARNING

Check the cable routing before each ride. The cables on both sides of the bike (rear brake line (non-drive) and rear derailleur (drive side) must:

- Measure 460-480 mm, see previous page.
- Be attached securely by the down tube guide, captured through the BB guide loop, and securely attached to the chainstay guides with cable ties to prevent cable sliding. Do not route under lower shock mount. See previous page.
- Be long enough when the suspension is fully compressed to ensure necessary cable slack. The photo above shows the state of slack with the suspension fully compressed (bottom-out).

You can be severely injured, paralyzed or killed in an accident if you ignore this warning.

Head Tube

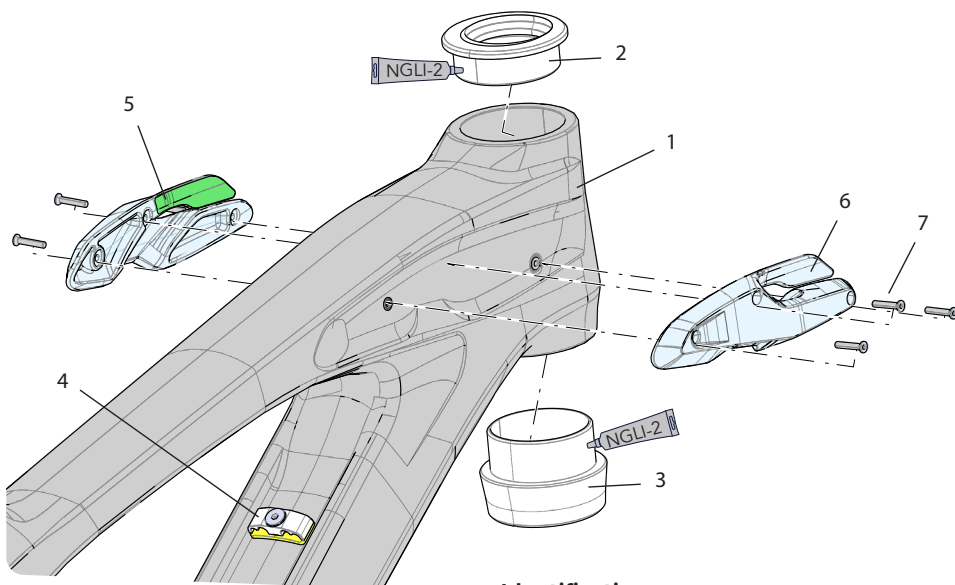

Identification

1. Head Tube
2. Headset Cup, Upper
3. Headset Cup, Lower
4. DT Cable Guide
5. Bumper, Left
6. Bumper, Right
7. Screws (6X)

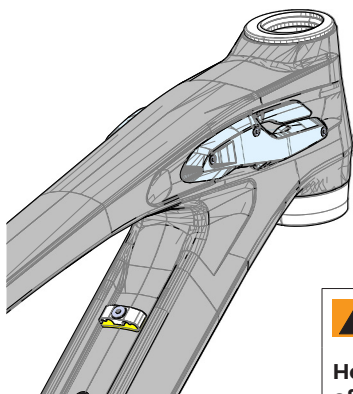

WARNING

Headset cups used must correspond with the set up of the frameset 27.5 in or 29 in. Identify by markings on cups. Do not interchange frames types and headset cups. Have headset cups removed and installed by a professional bike mechanic.

MAINTENANCE

The following table lists only supplemental maintenance items. Please consult your [GT Bicycle Owner's Manual](#) for more information on basic bike maintenance.

Item	Frequency
<p>Cable Routing - Make sure control cables are in place, undamaged and attached securely.</p> <p>Frame Protection - Check the various frame protectors (downtube, headtube, chainstay, swingarm on your bike. Make sure they are in place and in good condition.</p>	<p>Pre-Ride Inspection Before each ride.</p> <p>See pages 22 and 23!!</p>
<p>Damage Inspection - Clean and visually inspect entire bike frame/swing arm/linkage assembly for cracks or damage.</p>	<p>Before and after each ride</p>
<p>Check Tightening Torques - In addition to other component specific tightening torques for your bike, tighten according to the "Tightening Torques" information listed in this supplement.</p>	<p>Before each ride</p>
<p>Disassemble, clean, inspect, re-grease, replace worn or damaged parts in the following assemblies:</p> <ul style="list-style-type: none"> · SHOCK LINK · PIVOT AXLES · FRAME PIVOT BEARINGS 	<p>Excessive wear and damage can occur rapidly under aggressive and downhill riding conditions. Inspect these areas before each ride.</p>
<p>Fork and Shock- Consult the manufacturer's owner's manual for maintenance requirements.</p>	



WARNING

Any part of a poorly maintained bike can break or malfunction leading to an accident where you can be killed, severely injured or paralyzed.

Frequent checks are necessary to identify the problems that can lead to an accident. See "Inspect For Safety" in your [GT Bicycle Owners Manual](#).

REPLACEMENT PARTS

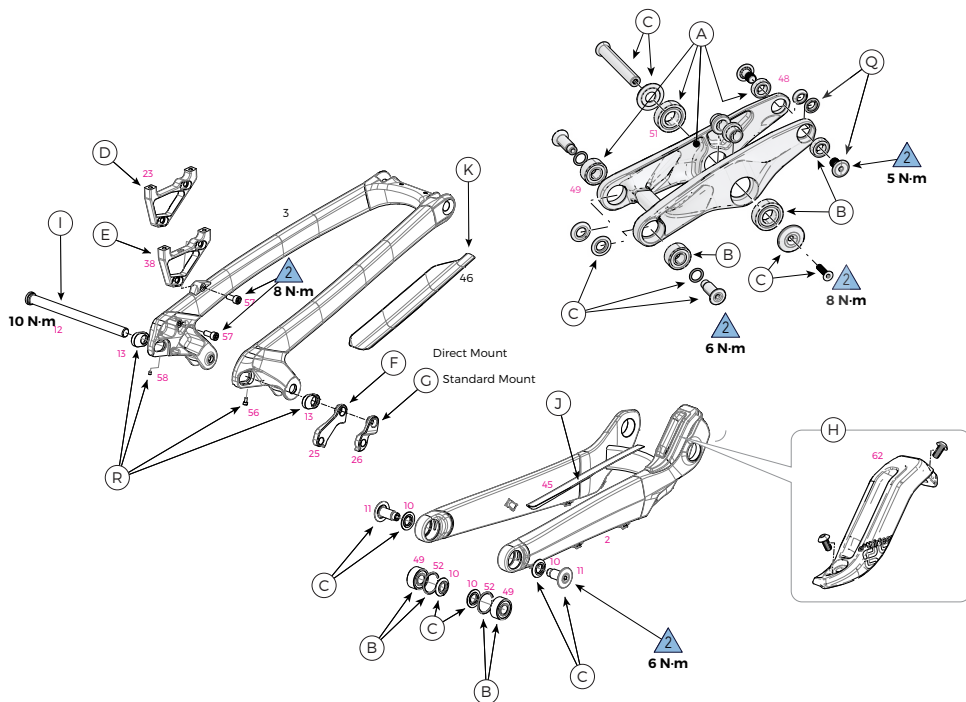

ID	Part Number	Description	27.5	29
A	K91089	Fury Suspension Link 27.5/29	✓	✓
B	K36189	Fury Pivot CS SS Link Brgs	✓	✓
C	K36199	Fury Pivot Hardware	✓	✓
D	K31049	ISO Shimano 203 mm Brake Mount	✓	✓
E	K31059	SRAM 200 mm Brake Mount	✓	✓
F	K33029	Derailleur Hanger TA DM SS 071	✓	✓

ID	Part Number	Description	27.5	29
G	K33039	Derailleur Hanger TA ST SS 072	✓	✓
H	K91109	Fury Idler Guide	✓	✓
I	K83009	Fury 148x12 Thru Axle	✓	✓
J	K34189	Fury Chainstay Protector	✓	✓
K	K34199	Fury Seatstay Protector	✓	✓
R	K91099	Dropout Thru Axle Flip Chips	✓	✓

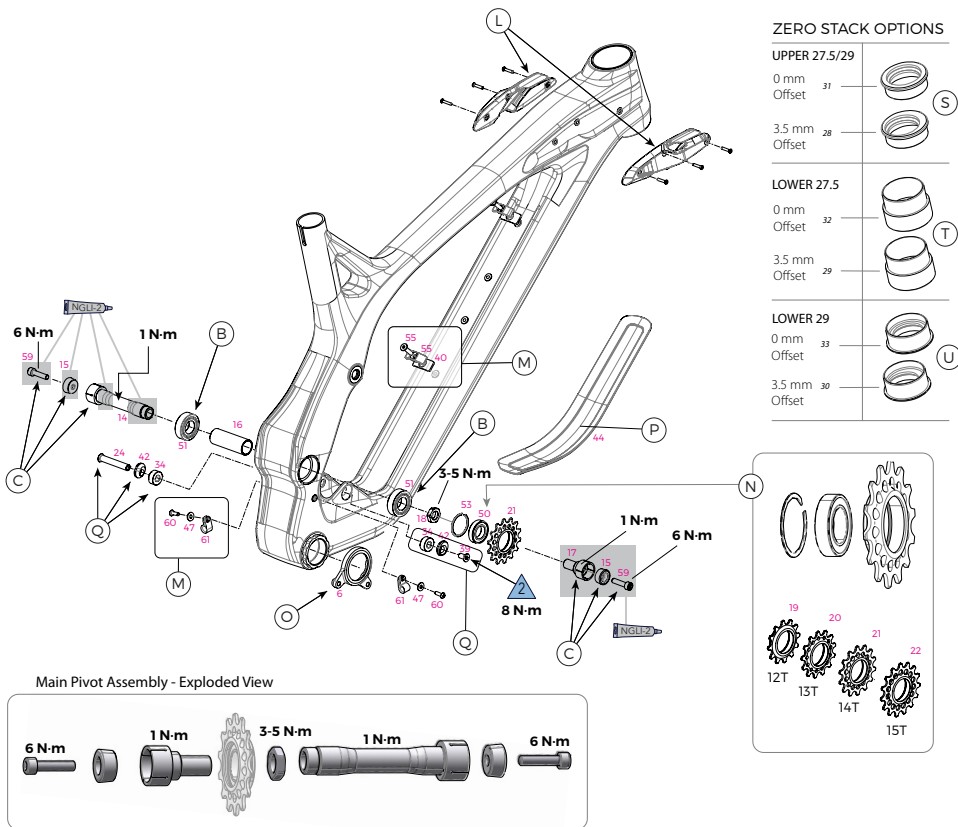

ID	Part Number	Description	27.5	29
L	K34119	Fury Top Tube Fork Bumper Plates	✓	✓
M	K32039	Fury Cable Guides DT ST	✓	✓
N	K2202912	Idler Cog with Bearing 12T	✓	✓
	K2202913	Idler Cog with Bearing 13T	✓	✓
	K2202914	Idler Cog with Bearing 14T	✓	✓
	K2202915	Idler Cog with Bearing 15T	✓	✓
O	K22039	GT ISCG Mount 2 Bolt	✓	✓

ID	Part Number	Description	27.5	29
P	K34179	Fury Downtube Protector	✓	✓
Q	K36209	Fury Shock Mount Hardware	✓	✓
S,T	K3504927	Headset Cups 0mm and 3.5mm Offsets 27.5	✓	
T,U	K3504929	Headset Cups 0mm and 3.5mm Offsets 29		✓



NOTES

Use this page to write /record important information about your bike : (e.g. maintenance history, dealer contact information, settings, etc.)

WWW.GTBICYCLES.COM

© 2018 Cycling Sports Group

2019 Fury Owner's Manual Supplement

134930 Rev. 1

GT USA

Cycling Sports Group, Inc.
1 Cannondale Way,
Wilton CT, 06897, USA
1-800-726-BIKE (2453)
www.gtbicycles.com

GT EUROPE

Cycling Sports Group Europe, B.V.
Hanzepoort 27, 7570 GC, Oldenzaal,
Netherlands +41 61 4879380
servicedeskeurope@cyclingsportsgroup.com

GT UK

Cycling Sports Group
Vantage Way, The Fulcrum,
Poole, Dorset, BH12 4NU
+44 (0)1202732288
sales@cyclingsportsgroup.co.uk